



STONHARD

HIGH-PERFORMANCE LINING SYSTEMS

ENGINEERED SOLUTIONS



COMPLETE CORROSION PROTECTION

The leader in seamless polymer protection for more than 95 years, Stonhard manufactures and installs Stonchem, an extensive line of coatings and linings products for harsh environments: secondary containment, processing areas, pits and trenches.

CUSTOMER SATISFACTION FROM START TO FINISH

Stonhard is dedicated to complete customer satisfaction. We offer a single-source warranty covering defects in materials and workmanship for a period of one full year from the date of installation. Our local Territory Managers and team of Regional Linings Managers work with you directly, supporting you through product evaluation, material selection and providing on-the-spot technical support. You always work with us and not with agents or distributors.

STONHARD
single
source



SELECTING THE BEST LINING SYSTEM IS ONLY THE BEGINNING TO SOLVING YOUR CORROSION

PROBLEMS. Engineering details, surface preparation and installation are critical factors affecting the long-term performance of your lining system. While these elements represent only 40% of the cost of a typical lining system, lack of attention to or elimination of these details leads to 90% of all lining failures – **90%!**

Stonhard's engineered solutions address all elements of your lining project. This approach minimizes your risk and provides maximum return on your investment. Consult your Stonhard Territory Manager or Regional Linings Manager to discuss the lining system that fits your needs.

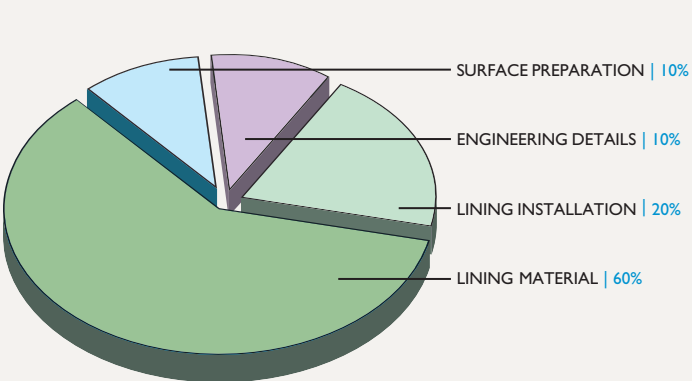

INSTALLED LINING COST

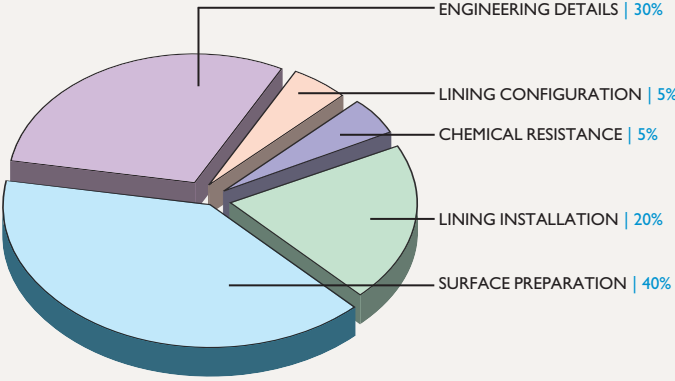

LINING PERFORMANCE PROBLEMS

Engineering Survey – Conducted by your local Stonhard Project Engineer. Over 300 Territory Managers and Regional Lining Specialists.

Polymer Technology – A complete family of polymer solutions to solve the toughest corrosion problems.

System Options – A full range of lining configurations to meet your exact physical requirements.

Engineering Details – The difference between long-term, successful performance and early lining failure. Engineering drawings are available to assist you in design specifications.

Installation – Over 200 specially trained installation teams. Stonhard takes full responsibility for products and workmanship.

Post-Installation Services – Detailed follow-up and inspection by your local Territory Manager.



Corrosive environments often require solutions for a variety of obstacles using a single system. A well designed lining must address two critical factors — chemical exposure and the physical demands of the application. An appropriate resin system ensures protection from and containment of the chemicals used in your application. Gathering information about the conditions of use (e.g. traffic conditions, exposure duration and frequency, maintenance procedures, thermal stresses, etc.) will ensure the best system is selected, guaranteeing long-term protection. Stonhard knows that superior solutions begin with state-of-the-art polymer technology and expert system engineering. Our complete line of resin chemistries is specifically formulated to meet the needs of any chemical environment — from mild splash and spill to severe immersion service.

POLYMER TECHNOLOGIES

300 Series

This general purpose series of products is based on a highly cross-linked Bisphenol A epoxy resin designed to protect concrete substrates against a broad range of chemicals in a wide variety of applications, including water and wastewater treatment facilities.

Best for exposure to low concentrations of inorganic acids and moderate concentrations of caustics.

*Stonchem 341 is NSF-61 approved; UL approved system for potable water storage tanks of 6,000 gallons or greater.

400 Series

State-of-the-art polyurea-polyurethane hybrid technology shapes this series of coatings. This unique polymer is created by a nucleophilic addition reaction between an amine- and hydroxyl-terminated resin and an isocyanate. This reaction allows for the instant formation of a tough, flexible film.

Best for exposure to petroleum products, caustics and moderate concentrations of acids. Systems suitable for use in water and wastewater treatment facilities.

*Stonchem 444 is NSF-61 approved; UL approved system for potable water storage tanks of 1,000 gallons or greater.

500 Series

The patented chemistry results in a hybrid epoxy resin combination producing modified cycloaliphatic and aliphatic amine hardeners. This unique blend creates a more resilient structure which optimizes the balance between chemical resistance, impact strength and thermal cycling resistance.

Best for exposure to alkalis, moderate acids and high molecular weight solvents.

NOTE: We offer an immersion grade, flake-filled tank lining suitable for chemical and water/wastewater applications. Ask us about Stonchem 541.

600 Series

This novolac epoxy resin is used to shape our most advanced epoxy system. The novolac epoxy is synthesized by selective epoxidation of the multiple phenolic hydroxyls of the novolac resin. The resultant, compact structure exhibits elevated temperature and chemical resistance.

Best for exposure to inorganic acids, concentrated sulfuric acid, aggressive solvents and alkalis.

700 Series

This series is engineered with a chlorendic acid-based, unsaturated polyester resin. This dense polymer network is physically strong and resistant to most oxidizing chemicals.

Best for exposure to nitric acid, chromic acid and hydrogen peroxide.

800 Series

A highly cross-linked vinyl ester resin forms the basis of this series. The combination of a small number of ester groups and a high degree of branching results in excellent thermal stability and broad-based chemical resistance.

Best for exposure to concentrated organic acids, inorganic acids, most solvents and alkalis.

After selecting the appropriate resin binder chemistry, the physical configuration of the system must be determined. The following chart provides an overview of Stonhard's standard system configurations, which are designed to address typical lining environments. After a thorough site survey, Stonhard will recommend a system or combination of systems customized to meet the specific requirements of every application.

The various resin chemistries described on Page 4 are identified in the system name by an **X**, with the last two numbers indicating the physical system configuration shown in the chart. All three numbers together designate a complete lining system. For example, Stonchem 601 indicates a 600 Series resin technology (novolac epoxy) with an X01 physical configuration.

	Applications/Performance Characteristics										Optional Properties		Configurations	
	OVER CRACKS	FOOT TRAFFIC	RUBBER WHEEL CARTS	STEEL WHEEL CARTS	FORKLIFT & TRUCK	GOUGE IMPACT	THERMAL SHOCK	THERMAL CYCLING	FLOURINE SERVICE	NON-SPARKING CONDUCTIVE	TEXTURE	NON-SILICA		
STONCHEM X01/X21/X81 25 mils	○	●	○	○	○	○	○	○	✓	✓	✓	✓		
STONCHEM X02/X22/X82 40 mils	○	●	○	○	○	○	○	○	✓	✓	✓	✓		
STONCHEM X10/620 135 mils	○	●	●	●	●	○	○	○	✓	✓	✓			
STONCHEM X30 60-250 mils	○	●	●	●	●	○	○	○				✓		
STONCHEM X55 40 mils	○	●	○	○	○	○	○	○				✓		
STONCHEM X56/X26/X86 60 mils	○	●	○	○	○	○	○	○	✓	✓	✓	✓		
STONCHEM X58/X58HD 125-160 mils	○	●	○	○	○	○	○	○	✓			✓		
STONCHEM X77 120 mils	○	●	○	○	○	○	○	○				✓		
STONCHEM X78/X28/X88 140 mils	○	●	○	○	○	○	○	○	✓	✓	✓	✓		
STONCHEM 441/444 30-120 mils	○	●	○	○	○	○	○	○				✓		
STONCHEM 457 80-120 mils	○	●	○	○	○	○	○	○				✓		

● = Recommended ○ = Recommended w/ Limitations ○ = Not Recommended
 X2X = Non-sparking, conductive systems
 XBX = Non-silica systems

ENGINEERING DETAILS



COMPLEMENTARY PRODUCTS

Grouts

Stonset CG4 – an ultra chemical-resistant, castable, novolac epoxy grout designed for setting pads, machinery and column pads and for resurfacing and protecting eroded areas with quick turnaround.

Stonset CG5 – a castable epoxy grout designed for setting heavy equipment, machinery, pumps, etc.

Stonset CR5 – a fast-setting, non-porous epoxy grout used to repair voids and erosions in concrete that is ideal for use under epoxy lining systems.

Stonset TG6 – fast setting, trowelable, polyurethane-based grout designed for repairing deep voids and erosion in concrete substrates.

Stonset TG8 – a quick-cure, vinyl ester grout used to repair deep voids and erosions in concrete substrates. For use under Stonchem 700 and 800 series systems only.

Stonset PM5 – a high-strength, epoxy patching material used to fill bug holes and voids on vertical and horizontal surfaces.

Stonset PM8 – a high-strength, vinyl ester patching material used to fill bug holes and voids on vertical surfaces.

Stonset PC3 – an epoxy-modified cementitious patching compound used for filling holes and form voids in vertical surfaces without adding significant thickness to the substrate.

Sealants/Elastomers

Stonflex MP7/MN7 – a polyurethane sealant for high-movement joints in horizontal and vertical surfaces.

Stonflex CR9 – a two-component, fluoro-elastomeric joint sealer that exhibits exceptional chemical resistance to most acids, alkalis and solvents.

Stonproof CT5 – a two-component, fiberglass-reinforced, flexible epoxy membrane designed for crack-bridging applications.

Stonproof XT7 – a two-component, liquid-applied, polyurethane/polymer hybrid used for waterproofing and crack bridging.



SEAMLESS LINING SYSTEMS

Stonhard's lining experts are devoted exclusively to concrete corrosion protection. And protection begins with proper design and engineering details. Our experience coating both primary and secondary containment areas gives us the ability to offer you the most safe, effective, long-term solutions, from products to installation. Stonhard also offers seamless floor protection to work in conjunction with your lining solutions.

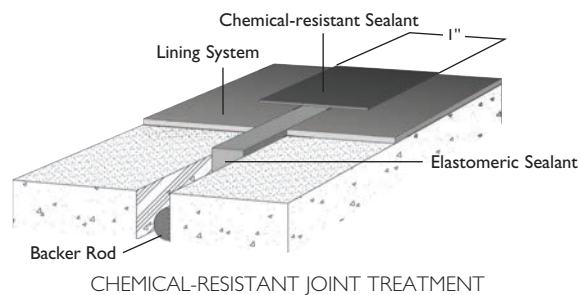
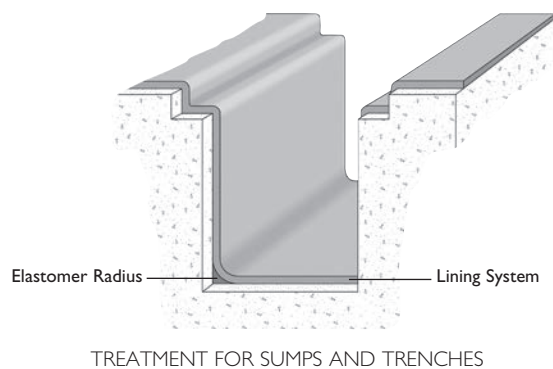
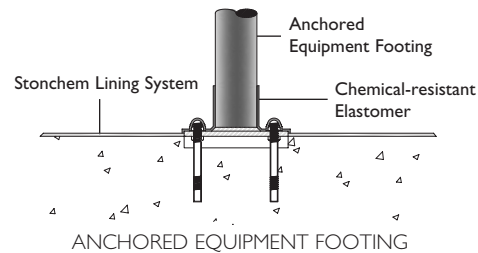
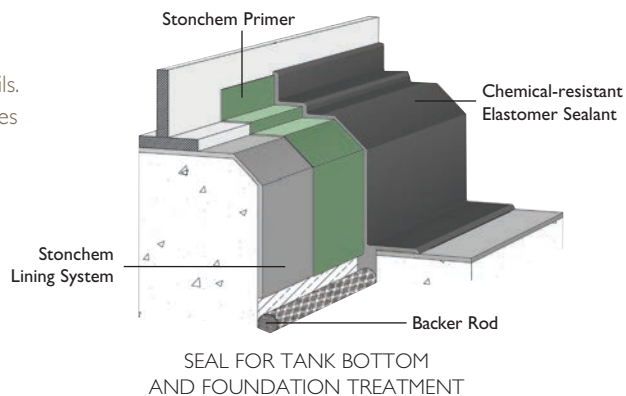
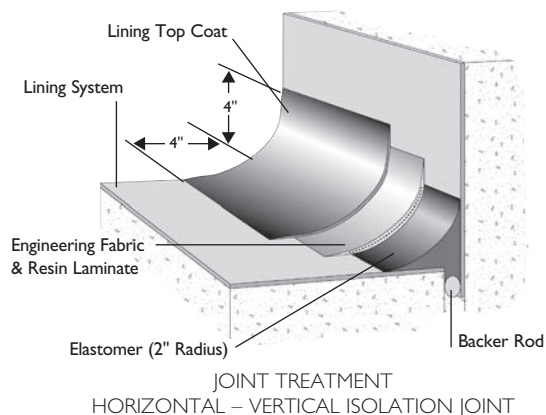
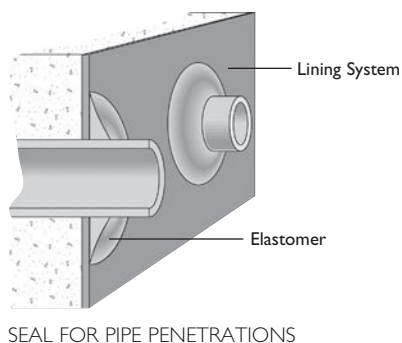
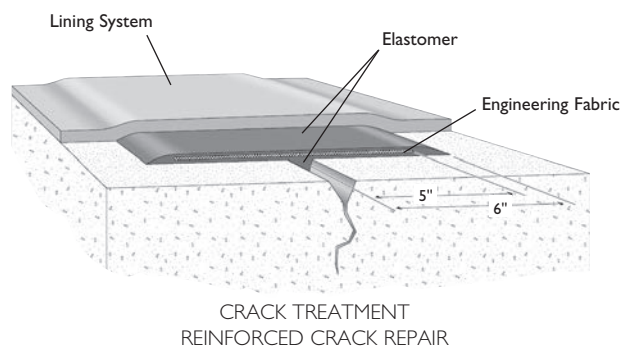

STONHARD is a global leader in manufacturing and installing seamless floor, wall and lining systems with sales operations in more than 65 countries. Stonhard has a direct sales force in North America, Europe, South Africa and parts of the Middle East, and works through a dedicated network of Stonhard affiliates throughout the rest of the world.

STONHARD®

1000 East Park Avenue
Maple Shade, NJ 08052

p 800.257.7953
f 856.321.7525

Stonhard Worldwide

Maple Shade, NJ, USA **HQ**
800.257.7953

Whitby, Ontario, Canada
(905) 430.3333

Mexico City, Mexico
(52) 55.9140.4500

Buenos Aires, Argentina
(54.3327) 44.2222

Nivelles, Belgium
(32) 67.493.710

Dubai, U.A.E.
(971) 4.3470460

Johannesburg, South Africa
(27) 11.254.5500

Shanghai, China
(86) 21.61838698

Melbourne, Australia
(03) 9587.7433

**U.S. Sales and
Distribution**
Maple Shade, NJ
Atlanta, GA
Dallas, TX
Chicago, IL
San Francisco, CA

a brand of

S THE
STONHARD
GROUP
FLOORS FOR EVERY ENVIRONMENT

Stonhard believes the information contained here to be true and accurate. Stonhard makes no warranty, expressed or implied based on this literature and assumes no responsibility for consequential or incidental damages in the use of these products and systems described, including any warranty of merchantability or fitness. Information contained here is for evaluation only. ©2017.

stonhard.com

